

## Flow Switches – Liquid

### Series FS6 High Sensitivity Liquid Flow Switches

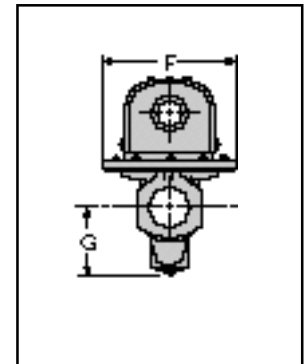

- For heavy duty applications where high sensitivity is required, such as water treatment systems, cooling systems for electronic circuits, compressors, booster pumps, and bearings, and other applications that need instant switching
- In-line configuration eliminates need for a pipe tee
- Very high flow capacity
- Actuates at extremely low flow rate
- Sizes available
  - 3/4" NPT
  - 1" NPT
- Single pole, double throw snap switch
- Switch compartment is completely sealed to protect it from the liquid
- Sensitivity adjusting screw makes flow adjustment easy
- Optional feature
  - BSPT threads
- Minimum temperature (fluid or ambient) 32°F (0°C)
- Maximum temperature 225°F (107°C)
- Maximum operating pressure 100 psi (7 kg/cm<sup>2</sup>)

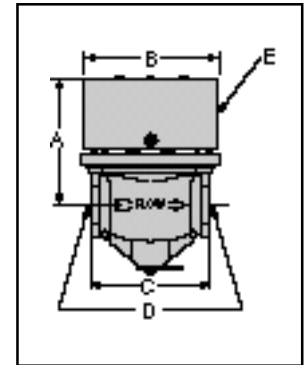

#### Dimensions, in. (mm)

A	B	C	D NPT	E	F	G
3½ (89)	3 <sup>23</sup> / <sub>32</sub> (94.4)	3 <sup>3</sup> / <sub>8</sub> (86)	¾ or 1	7/8 (22)	3¾ (95)	2 (51)

### Model FS6-W High Sensitivity Liquid Flow Switches

- For applications requiring a water-tight, dust-tight, or a NEMA 4X rated flow switch

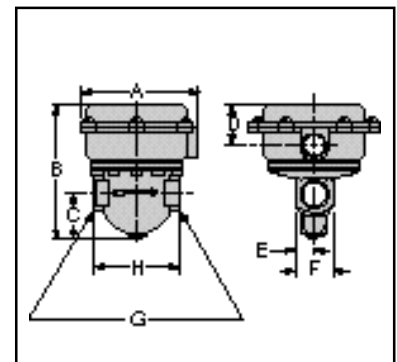

#### Dimensions, in. (mm)

A	B	C	D	E	F	G NPT	H
5 (127)	5¾ (146)	2 (51)	1½ (41)	2 <sup>9</sup> / <sub>32</sub> (23)	1 <sup>13</sup> / <sub>16</sub> (46)	¾ or 1	3 <sup>3</sup> / <sub>8</sub> (86)

## Electrical Ratings

Voltage	Motor Switch Rating (Amperes)		Pilot Duty
	Full Load	Locked Rotor	
120 VAC	7.4	44.4	125 VA at 120 or 240 VAC 50 or 60 cycles
240 VAC	3.7	22.2	

## Flow Rates

Pipe Size NPT in.	Settings	Mode of Operation		Max. Flow Rate gpm (lpm)
		Flow gpm (lpm)	No Flow gpm (lpm)	
3/4 or 1	Factory or			70 (265)
	Minimum	.12 (.45)	.06 (.23)	
	Maximum	2.5 (9.46)	1.5 (5.68)	

Values are ± 10%

## Ordering Information

Model Number	Part Number	Description	Weight lbs. (kg)
FS6-3/4	115400	High sensitivity flow switch 3/4" NPT body	4.5 (2)
FS6-J-3/4	115550	FS6-3/4 w/BSPT pipe threads	4.5 (2)
FS6-1	115600	High sensitivity flow switch 1" NPT body	4.5 (2)
FS6-J-1	115650	FS6-1 w/BSPT pipe threads	4.5 (2)
FS6-W-3/4	115651	FS6-3/4 w/NEMA 4X enclosure	4.5 (2)
FS6-WJ-3/4	115653	FS6-W-3/4 w/BSPT connections	4.5 (2)
FS6-W-1	115652	FS6-1 w/NEMA 4X enclosure	4.5 (2)
FS6-WJ-1	115654	FS6-W-1 w/BSPT connections	4.5 (2)
FS6-J-3/4-E	115551	FS6-J-3/4 - CE conformance rated	4.5 (2)
FS6-J-1-E	115655	FS6-J-1 - CE conformance rated	4.5 (2)
FS6-WJ-3/4-E	115656	FS6-WJ-3/4 - CE conformance rated	4.5 (2)
FS6-WJ-1-E	115657	FS6-WJ-1 CE conformance rated	4.5 (2)

See page 132 for CE Conformance information

**NOTE: DO NOT USE LIQUID FLOW SWITCHES ON SYSTEMS WITH FLOW GREATER THAN 10 FEET (3M) PER SECOND.**

## Liquid Flow Switches

The flow of liquids in pipelines plays an important role in industry and commerce. Under most circumstances it is essential to know whether or not there is a flow in a pipeline, and to act upon that knowledge. That is the reason for, and the function of, McDonnell & Miller Flow Switches.

A complete line of Liquid Flow Switches has been developed for a wide range of applications and literally hundreds of uses, including:

- Air Conditioning
- Hot Water Space Heating Systems
- Hot Water Supply Systems
- Pump Systems
- Water Cooled Equipment
- Blending or Additive Systems
- Liquid Transfer Systems
- Fire Sprinkler Systems
- Water Treatment Systems
- Swimming Pool Chlorination
- Industrial Laser Coolant System

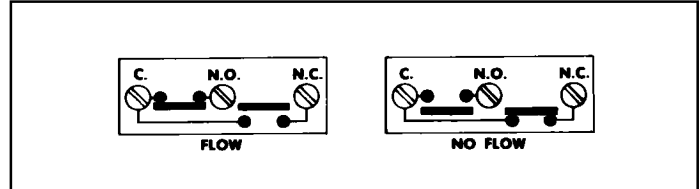

In the tables of flow rates included in this catalog the word “Flow” means that switch will close one circuit and open the other, when flow rate is increased to the rate shown.

The words “No-Flow” mean the switch will reverse position—open first circuit and close the second—when flow rate is decreased to the rate shown.

**NOTE: DO NOT USE LIQUID FLOW SWITCHES ON SYSTEMS WITH FLOW GREATER THAN 10 FEET (3M) PER SECOND.**

Flow Switches	NEMA Enclosure
All Models	Type 1—General purpose indoor
FS1W, FS6W FS7-4W, FS8W	Type 4X—Watertight, Dust tight and Corrosion resistant
FS7-4E	Type 7—Hazardous Location (Class 1—Group C or D) Type 9—Hazardous Location (Class 2—Group E, F or G)

Models FS74E, FS74SE Flow Switches are Underwriters Laboratories Inc. Listed for use in these hazardous locations:

**Class I, Division I, Group C** – Atmospheres containing ethylether vapors, ethylene or cyclopropane.

**Class I, Division I, Group D** – Atmospheres containing gasoline, petroleum, naphtha, benzene, butane, propane, alcohols, acetone, benzol, lacquer solvent vapors or natural gas.

**Class II, Division I, Group E** – Atmospheres containing dust of aluminum, magnesium or their commercial alloys.

**Class II, Division I, Group F** – Atmospheres containing carbon black, coal or coke dust.

**Class II, Division I, Group G** – Atmospheres containing flour, starch or grain dusts.

Note: For other listings contact the factory.

### Mounting Methods

