

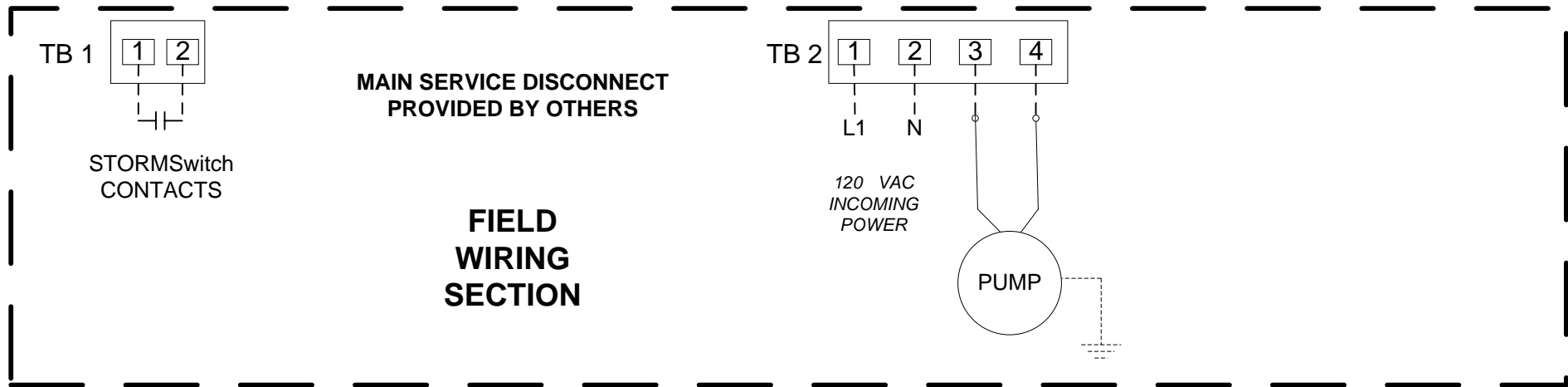

- NOTES**
1. PANEL SPECIFICATIONS: NEMA 4X ENCLOSURE  
CONTROL SECTION  
VOLTAGE: 24 VAC  
PUMP CIRCUIT  
VOLTAGE: 120VAC
  2. DASHED LINES REPRESENT FIELD WIRING REQUIRED
  3. CONNECT GROUND TERMINAL IN BOX TO A GOOD GROUND



TEMPERATURE RATING OF FIELD INSTALLED CONDUCTORS MUST BE AT LEAST 140 DEG. F. (60 DEG. C.) FIELD WIRING TERMINALS AND GROUND LUGS WILL ACCEPT COPPER CONDUCTORS ONLY. TORQUE RATING OF FIELD WIRING TERMINAL CLAMPING SCREWS IS 7.1 – 8.9 IN/LBS FOR TB1 & TB2, 10.6-12.3 IN/LBS FOR TB3, AND 45 IN/LBS FOR GROUND LUGS.

	<b>ATTITUDE TECHNOLOGY, INC.</b>			
	<b>STORMController 112 WIRING DIAGRAM</b>			
(866) 283-8320	SIZE LTR	DATE 09-06-2005	DWG NO PRO11-356	REV
WWW.ATTITUDETECHNOLOGY.COM	SCALE NTS	DWNBY:DEM	SHEET	1 OF 1